

# Parker Hannifin Instrumentation Group China

## DY Series 1-Piece Ball Valve

Catalog 1001C-DY



### General Description

DY series 1-piece, stainless steel ball valves provide total shut-off capability for services up to 69 Bar (1000 PSI).

### Features

- Ball valve bodies are machined from CF-8M stainless steel castings, equivalent of 316 stainless steel which is suited for corrosive environments.
- Highly inert PTFE seats and seals provide resistance to chemical corrosion.
- For chemical and industrial applications.
- Blowout proof stem design, 316 stainless ball and a special design handle enable increased turn and leverage for ease of opening and closing.
- 100% factory tested.

### Options

- Locking device

### Specifications

Working Pressure	69 Bar (1000 PSI)
Temperature Ratings	-60 °F to 430 °F
Body Material	CF8M Stainless Steel 316SS Cast Equivalent
Ball and Stem Material	316 Stainless Steel
End Type	Threaded



Model Shown: 16F-DY16L-T-SS

### Pressure vs. Temperature

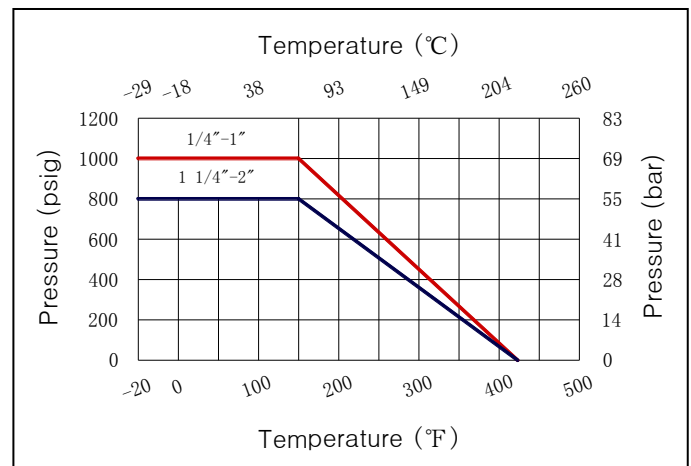

ENGINEERING YOUR SUCCESS.

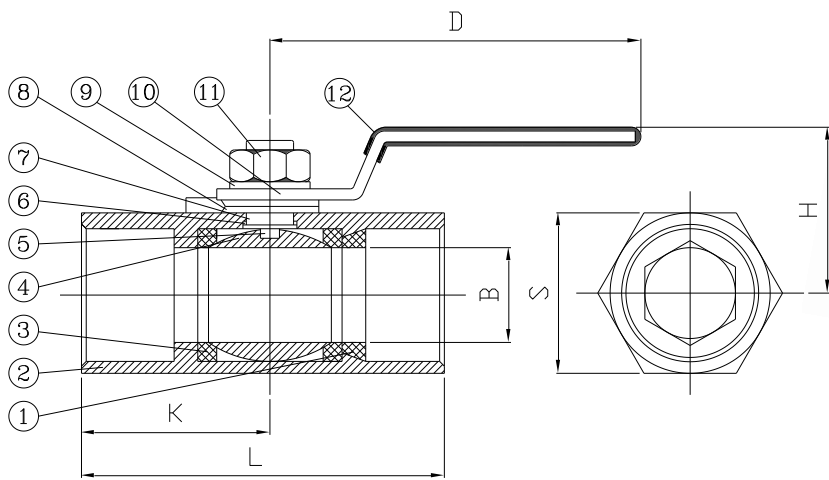

## Materials List

Item	Part	Material
1	Insert	CF8M
2	Body	CF8M
3	Seat	PTFE
4	Ball	SS 316
5	Stem	SS 316
6	Thrust Washer	PTFE
7	Stem Packing	PTFE
8	Gland Washer	SS 304
9	Washer	SS 304
10	Handle	SS 304
11	Nut Stopper	SS 304
12	Sleeve	Plastic

## Dimensions (mm)

Part No.	Size	B	H	D	L	S	K	W(kg)
4F-DY4L-T-SS	1/4"	5	38	62.5	39	17	19	0.07
6F-DY6L-T-SS	3/8"	7	40	73	44	21	21	0.11
8F-DY8L-T-SS	1/2"	9.2	51	85	56.5	25	27.5	0.18
12F-DY12L-T-SS	3/4"	12.5	53	87	59	32	30	0.26
16F-DY16L-T-SS	1"	16.0	56	107	71	38	36	0.42
20F-DY20L-T-SS	1 1/4"	20	61	107	78	49	40	0.75
24F-DY24L-T-SS	1 1/2"	25	68	130	83	53	42.5	0.85
32F-DY32L-T-SS	2"	32	73	130	100	65	51	1.35

## How to Order

The correct part number is easily derived from the following number sequence. The six product characteristics required are coded as shown below.

**Example: 8F - DY8L - T - SS** Describes a DY8L Two-Way Ball Valve with 1" female NPT end connections for inlet and outlet ports, PTFE seals, and stainless steel construction.

8	F	DY8	L	T	SS
Port Size	Inlet / Outlet Ports	Valve Series	Valve Configuration	Seal Material	Body Material
4	F - Female NPT	DY4	L - 2 Way	T - PTFE	SS - Stainless Steel
6		DY6			
8		DY8			
12		DY12			
16		DY16			
20		DY20			
24		DY24			
32		DY32			

Parker Hannifin Fluid Power Systems & Components (Shanghai) Co., Ltd  
Parker Hannifin Instrumentation Group China  
No.2 Workshop, 786 Wangqiao Road, Jinqiao Processing Southern Zone, Shanghai  
201201, China  
Tel: 86 21 5838 3030  
Fax: 86 21 5838 2428



ENGINEERING YOUR SUCCESS.